

NH fuse-links gG 400VAC

double indicator/isolated gripping-lugs size 000, 00, 1, 2, 3

LOW VOLTAGE IEC FUSES

IEC NH FUSE-LINKS



The NH system is classified among plug-in fuse systems and is composed of:

- fuse-base (possibly including terminal covers and phase barriers)
- fuse-link with blade contact
- fuse-link replacement device (LV HRC fuse puller)

Since the design of this system cannot guarantee non-interchangeability of rated current it must be handled by a qualified professional.

Type “gG” NH fuse-links are full range breaking capacity fuse-links and are used to protect cables and equipment. They can interrupt any current surge, from the lowest fusing current up to their breaking capacity, and so can be used alone as protection. They also protect electrical devices and industrial set-ups from the electrodynamic effects of very high short-circuit currents.

Rated Power Dissipation values of Mersen NH fuse-links 400VAC are below the maximum values required by standard IEC 60269.

TECHNICAL DATA OVERVIEW

Voltage AC	400 VAC
Ampere Range (A)	2 ... 630 A
Size per Standard	Sizes 000 to 3
Speed/Characteristic	gG
I.R. AC (IEC)	100 kA
Body Material	ceramic
Contact Materials	copper, silver-plated

FEATURES & BENEFITS

- Dimensions according to DIN 43 620 Parts 1 to 4
- Isolated metal gripping lugs (SGL)
- Double indicator
- Lead free contact blades
- 0% cadmium

APPLICATIONS

- gG: general purpose cable and line protection

STANDARDS

- VDE 0636 Part 201
- IEC 60269-1 and -2



NH fuse-links gG 400VAC

double indicator/isolated gripping-lugs size 000, 00, 1, 2, 3

PRODUCT RANGE



NH000GG40V100-1

Size 000 gG 400VAC isolated gripping-lugs

Catalog number	Item number	Rated voltage AC (IEC)	Rated current I _n	Power dissipation at I _n	Width	Package	Weight
NH000GG40V2-1	P223688	400 V	2 A	0.7 W	20.8 mm	3	0.12 kg
NH000GG40V6-1	R223690	400 V	6 A	1.3 W	20.8 mm	3	0.12 kg
NH000GG40V16-1	T223692	400 V	16 A	1.6 W	20.8 mm	9	0.12 kg
NH000GG40V20-1	V223693	400 V	20 A	1.9 W	20.8 mm	9	0.12 kg
NH000GG40V25-1	W223694	400 V	25 A	2.2 W	20.8 mm	9	0.12 kg
NH000GG40V32-1	X223695	400 V	32 A	2.7 W	20.8 mm	9	0.12 kg
NH000GG40V35-1	Y223696	400 V	35 A	3.1 W	20.8 mm	9	0.12 kg
NH000GG40V40-1	Z223697	400 V	40 A	3.5 W	20.8 mm	9	0.12 kg
NH000GG40V50-1	A223698	400 V	50 A	3.9 W	20.8 mm	9	0.12 kg
NH000GG40V63-1	B223699	400 V	63 A	5.2 W	20.8 mm	9	0.12 kg
NH000GG40V80-1	C223700	400 V	80 A	5.3 W	20.8 mm	9	0.12 kg
NH000GG40V100-1	D223701	400 V	100 A	5.7 W	20.8 mm	9	0.12 kg



NH00GG40V125-1

Size 00 gG 400VAC isolated gripping-lugs

Catalog number	Item number	Rated voltage AC (IEC)	Rated current I _n	Power dissipation at I _n	Width	Package	Weight
NH00GG40V125-1	G223704	400 V	125 A	7.4 W	29.5 mm	3	0.2 kg
NH00GG40V160-1	H223705	400 V	160 A	8.3 W	29.5 mm	3	0.2 kg



NH1GG40V250-1

Size 1 gG 400VAC isolated gripping-lugs

Catalog number	Item number	Rated voltage AC (IEC)	Rated current I _n	Power dissipation at I _n	Width	Package	Weight
NH1GG40V35-1	V223716	400 V	35 A	4 W	29.5 mm	3	0.28 kg
NH1GG40V50-1	W223717	400 V	50 A	5.2 W	29.5 mm	3	0.28 kg
NH1GG40V63-1	X223718	400 V	63 A	6.8 W	29.5 mm	3	0.28 kg
NH1GG40V80-1	Y223719	400 V	80 A	6.2 W	29.5 mm	3	0.28 kg
NH1GG40V100-1	Z223720	400 V	100 A	8.6 W	29.5 mm	3	0.28 kg
NH1GG40V125-1	A223721	400 V	125 A	9.8 W	29.5 mm	3	0.28 kg
NH1GG40V160-1	B223722	400 V	160 A	12.4 W	39.5 mm	3	0.42 kg
NH1GG40V200-1	C223723	400 V	200 A	14.4 W	39.5 mm	3	0.42 kg
NH1GG40V224-1	D223724	400 V	224 A	15.6 W	39.5 mm	3	0.42 kg
NH1GG40V250-1	E223725	400 V	250 A	17.6 W	39.5 mm	3	0.42 kg



NH2GG40V315-1

Size 2 gG 400VAC isolated gripping-lugs

Catalog number	Item number	Rated voltage AC (IEC)	Rated current I _n	Power dissipation at I _n	Width	Package	Weight
NH2GG40V35-1	L227250	400 V	35 A	4.1 W	39.5 mm	3	0.42 kg
NH2GG40V50-1	M227251	400 V	50 A	5.4 W	39.5 mm	3	0.42 kg
NH2GG40V63-1	N227252	400 V	63 A	6.8 W	39.5 mm	3	0.42 kg
NH2GG40V80-1	X223741	400 V	80 A	6.4 W	39.5 mm	3	0.42 kg
NH2GG40V100-1	Y223742	400 V	100 A	8.1 W	39.5 mm	3	0.42 kg
NH2GG40V125-1	Z223743	400 V	125 A	10.2 W	39.5 mm	3	0.42 kg
NH2GG40V160-1	A223744	400 V	160 A	10.8 W	39.5 mm	3	0.42 kg
NH2GG40V200-1	B223745	400 V	200 A	15.2 W	39.5 mm	3	0.42 kg
NH2GG40V224-1	C223746	400 V	224 A	14.7 W	39.5 mm	3	0.42 kg
NH2GG40V250-1	D223747	400 V	250 A	17.1 W	39.5 mm	3	0.42 kg
NH2GG40V315-1	E223748	400 V	315 A	20.1 W	51 mm	3	0.64 kg
NH2GG40V355-1	F223749	400 V	355 A	22.6 W	51 mm	3	0.64 kg
NH2GG40V400-1	G223750	400 V	400 A	25.4 W	51 mm	3	0.64 kg

NH fuse-links gG 400VAC

double indicator/isolated gripping-lugs size 000, 00, 1, 2, 3

PRODUCT RANGE



NH3GG40V500-1

Size 3 gG 400VAC isolated gripping-lugs

Catalog number	Item number	Rated voltage AC (IEC)	Rated current I_n	Power dissipation at I_n	Width	Package	Weight
NH3GG40V250-1	H223751	400 V	250 A	15.4 W	51 mm	1	0.65 kg
NH3GG40V315-1	J223752	400 V	315 A	19.8 W	51 mm	1	0.65 kg
NH3GG40V400-1	K223753	400 V	400 A	25.1 W	51 mm	1	0.65 kg
NH3GG40V500-1	L223754	400 V	500 A	31.1 W	70 mm	1	1.05 kg
NH3GG40V630-1	M223755	400 V	630 A	39 W	70 mm	1	1.05 kg

TECHNICAL DATA

	Size 000	Size 00	Size 1	Size 2	Size 3
Size	000	00	1	2	3
Rated current	2 ... 100 A	125 ... 160 A	35 ... 250 A	35 ... 400 A	250 ... 630 A
Rated breaking capacity AC	100 kA	100 kA	100 kA	100 kA	100 kA
Rated voltage AC	400 V	400 V	400 V	400 V	400 V
Indication System	double indicator	double indicator	double indicator	double indicator	double indicator
Width	21 mm	30 mm	40 mm	52 mm	72 mm

NH fuse-links gG 400VAC

double indicator/isolated gripping-lugs size 000, 00, 1, 2, 3

TIME CURRENT CHARACTERISTIC CURVES

Size 000

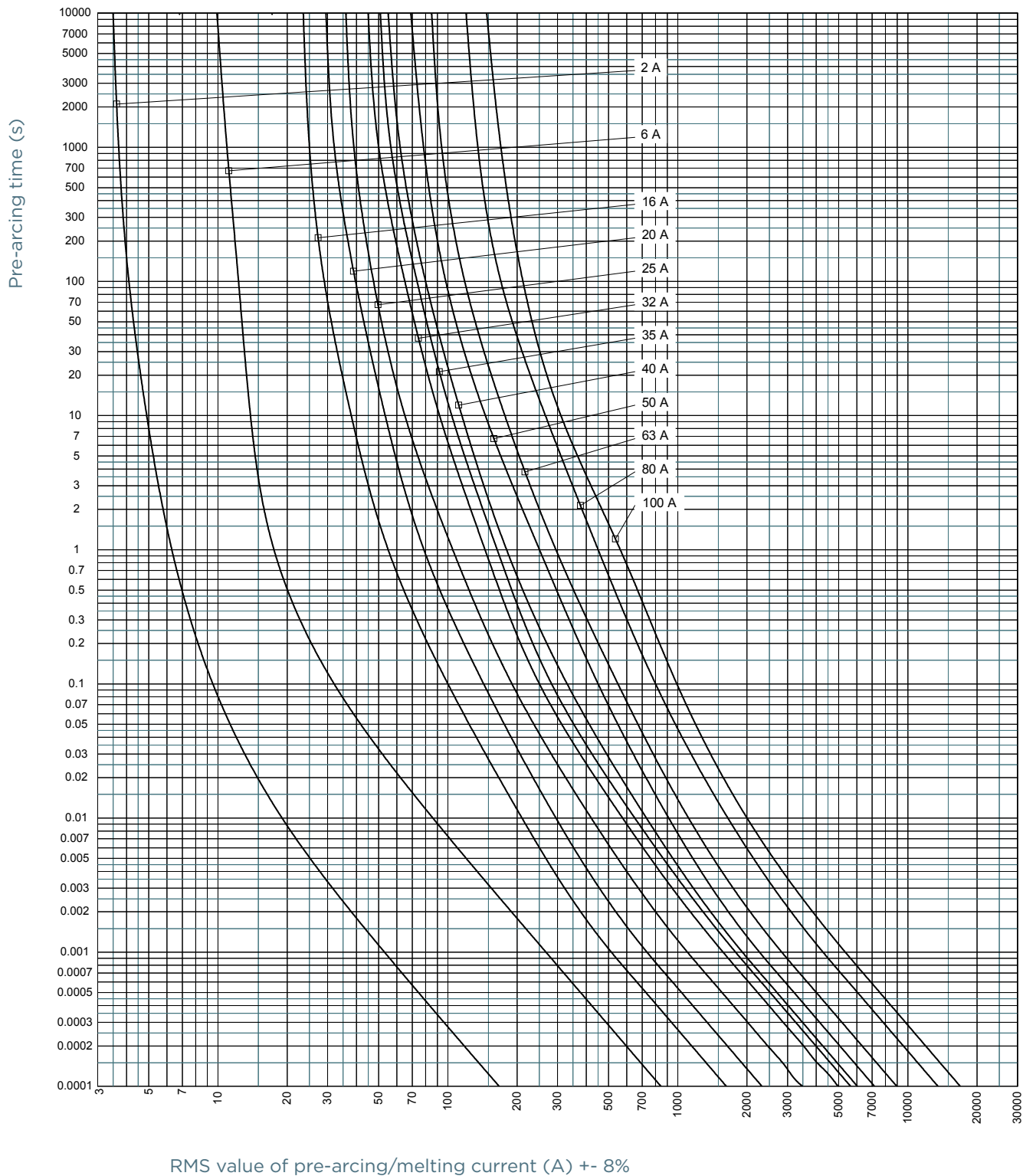

MERSEN reserves the right to change, update or correct, without notice, any information contained in this datasheet.

TIME CURRENT CHARACTERISTIC CURVES

Size 00

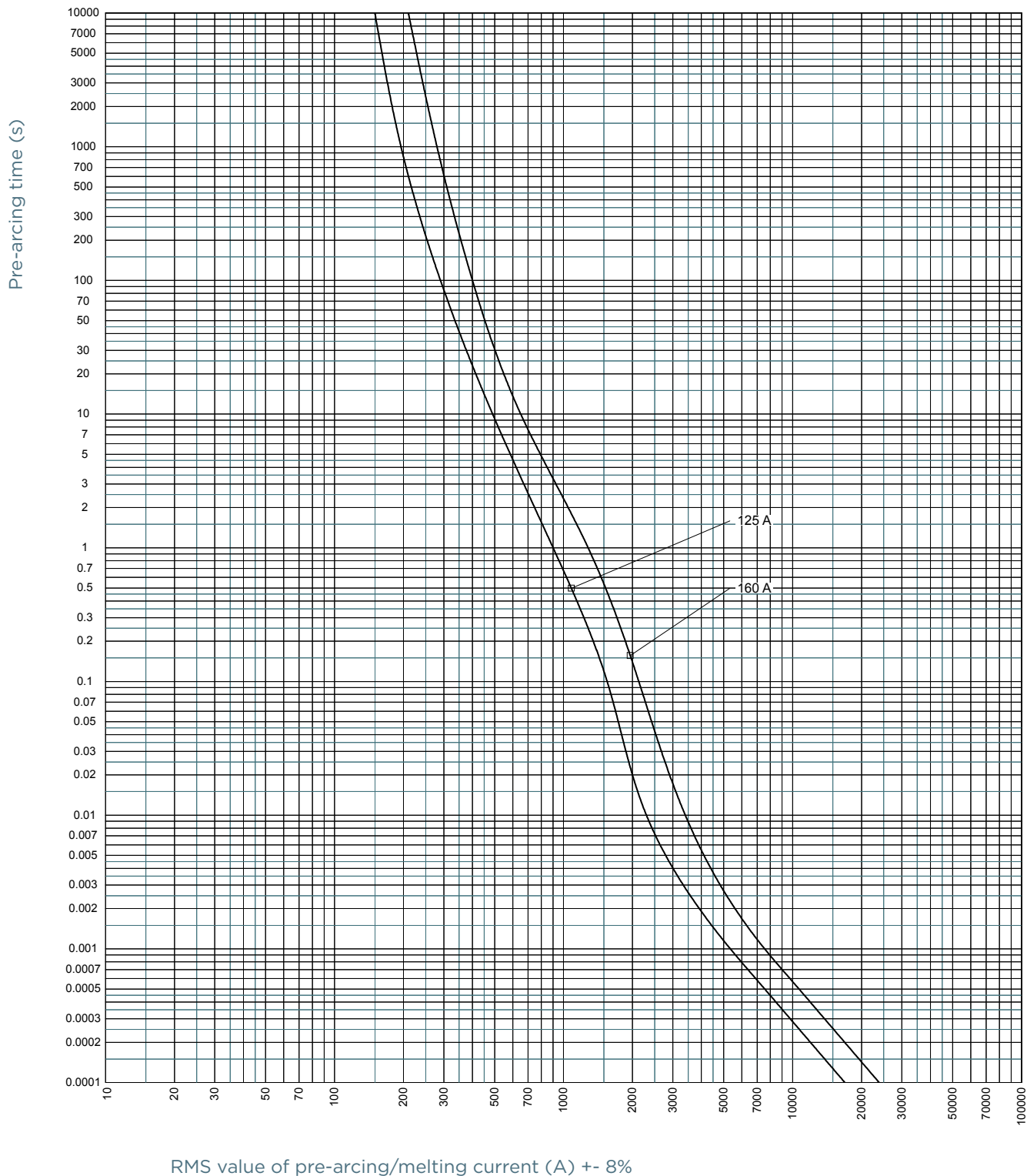

MERSEN reserves the right to change, update or correct, without notice, any information contained in this datasheet.

TIME CURRENT CHARACTERISTIC CURVES

Size 1

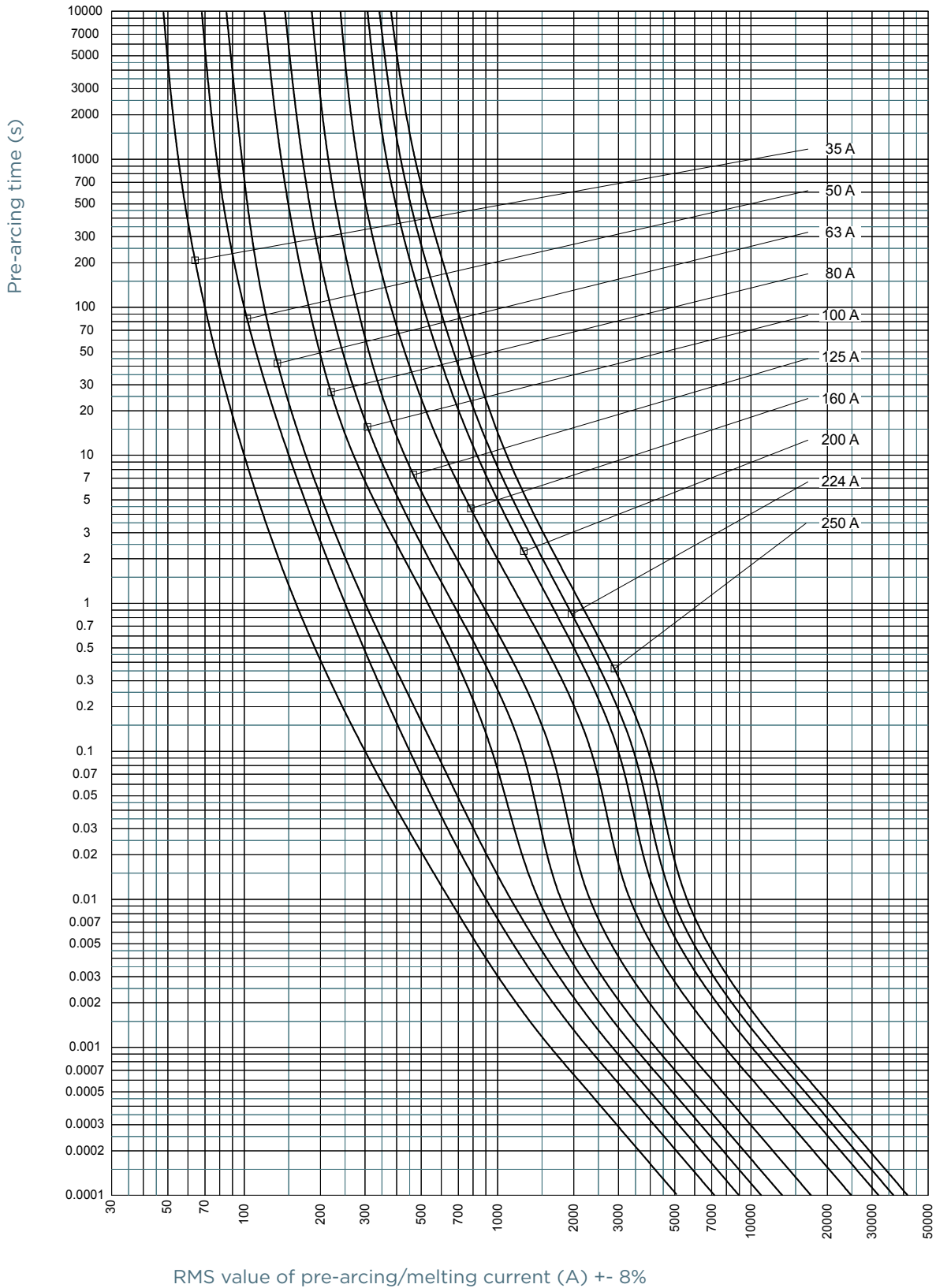

MERSEN reserves the right to change, update or correct, without notice, any information contained in this datasheet.

TIME CURRENT CHARACTERISTIC CURVES

Size 2

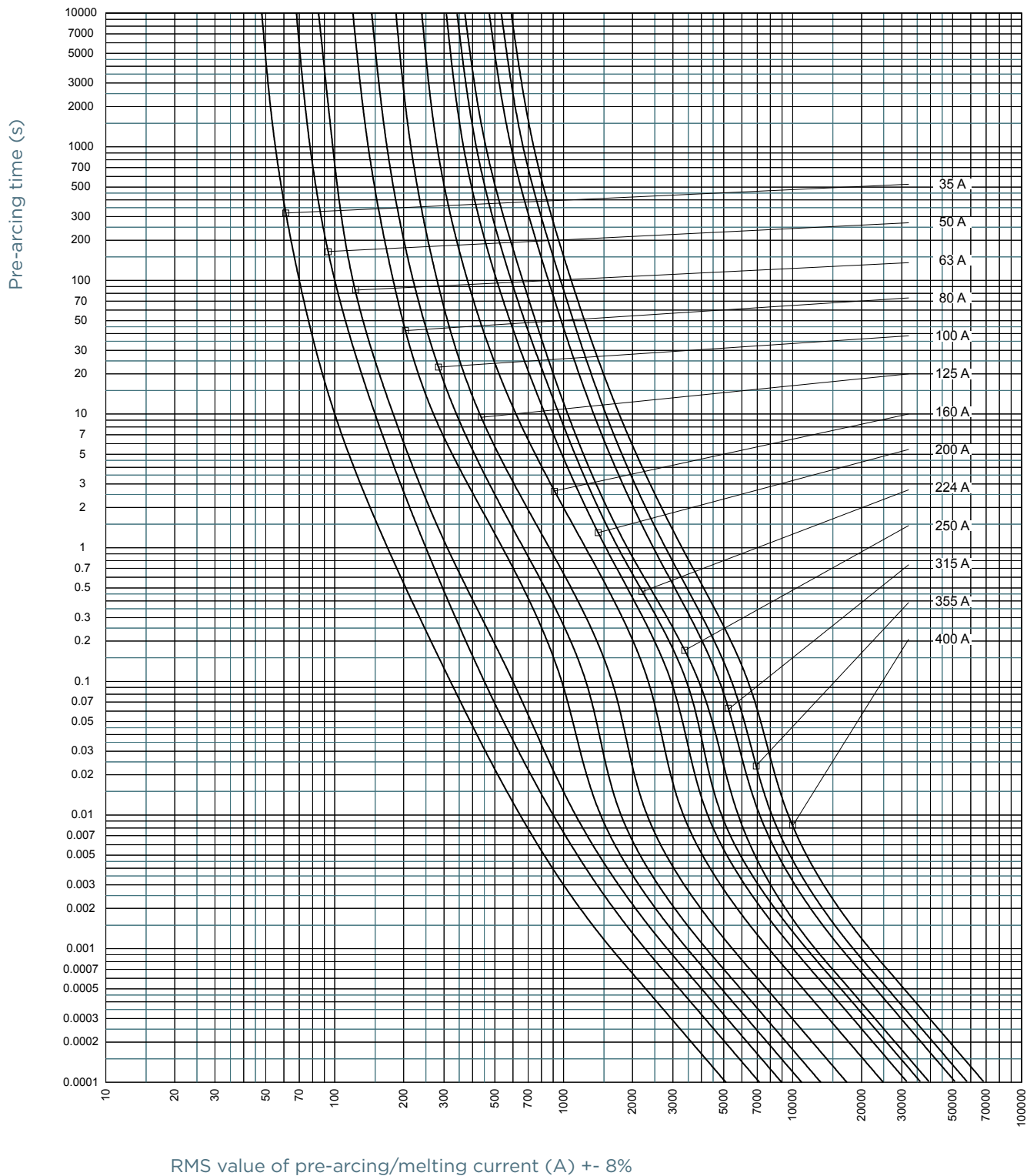

MERSEN reserves the right to change, update or correct, without notice, any information contained in this datasheet.

TIME CURRENT CHARACTERISTIC CURVES

Size 3

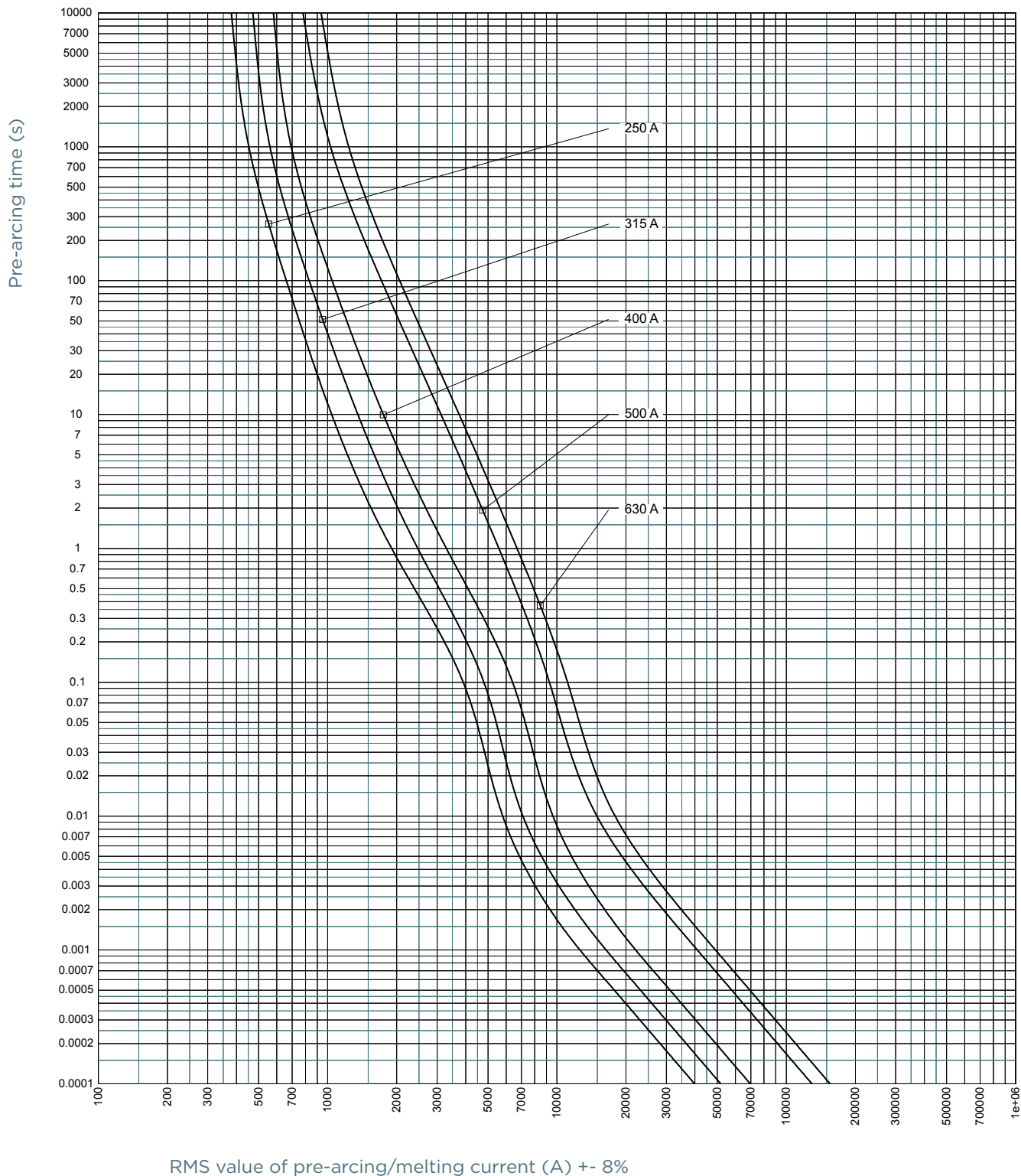

MERSEN reserves the right to change, update or correct, without notice, any information contained in this datasheet.

CUT-OFF CURRENT CHARACTERISTIC

Size 000

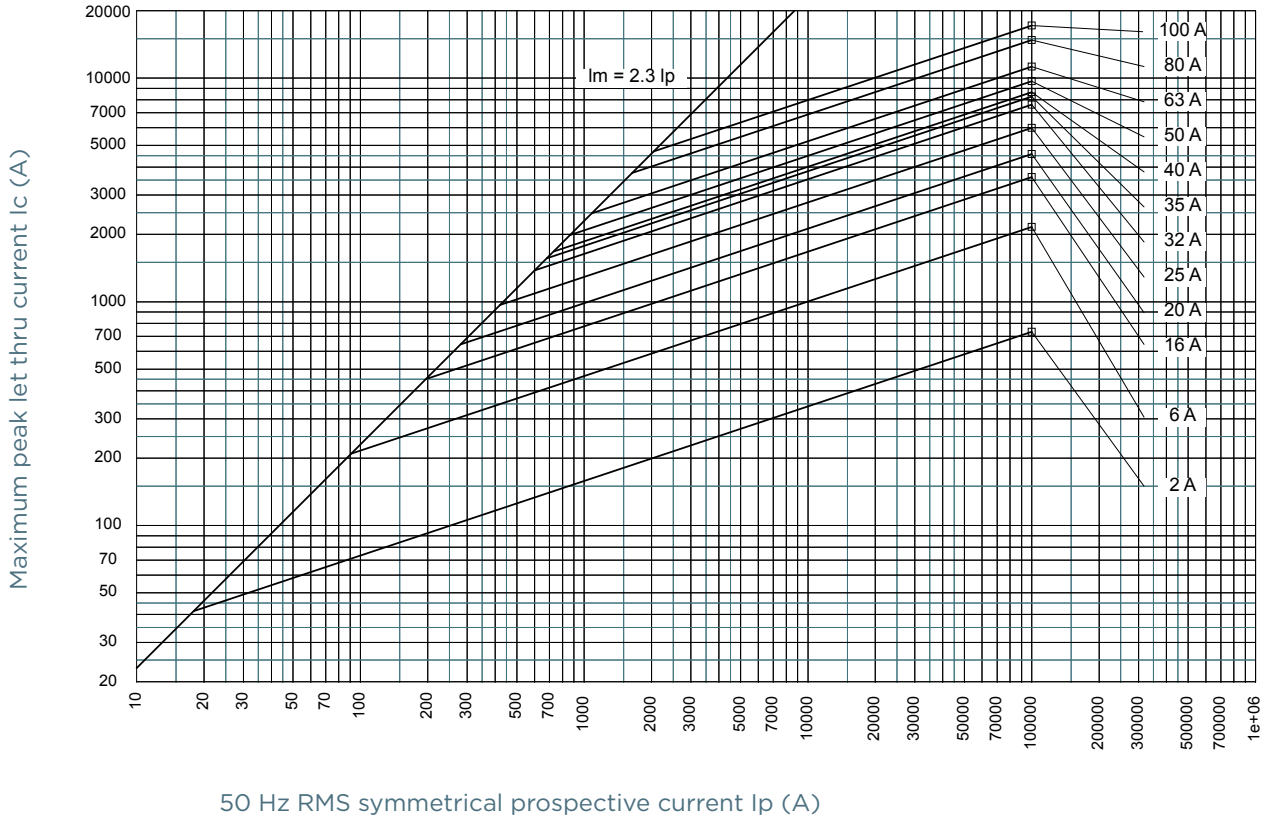

Size 00

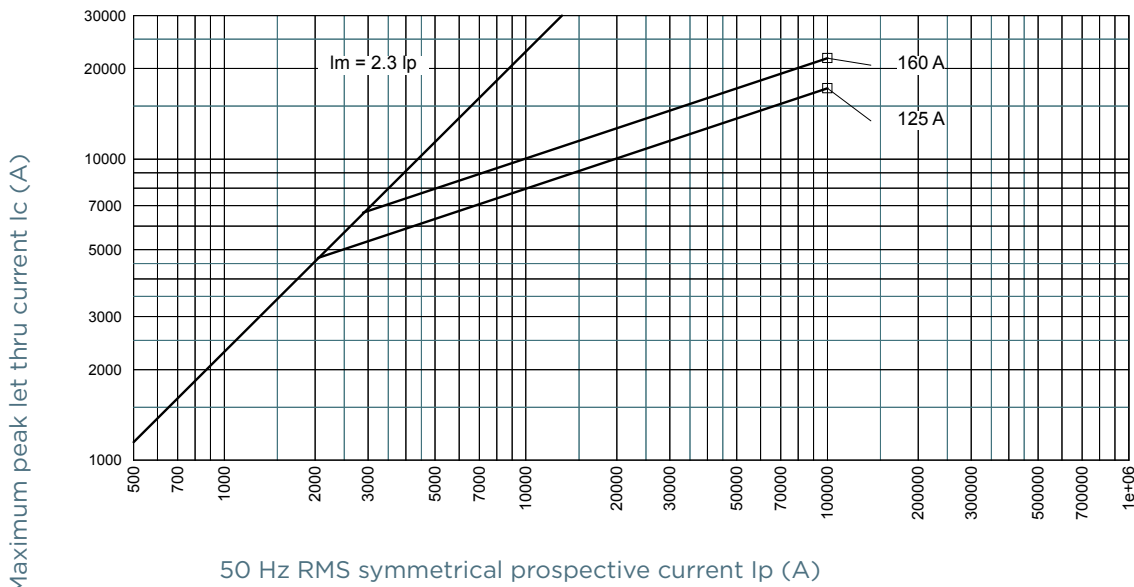

CUT-OFF CURRENT CHARACTERISTIC

Size 1

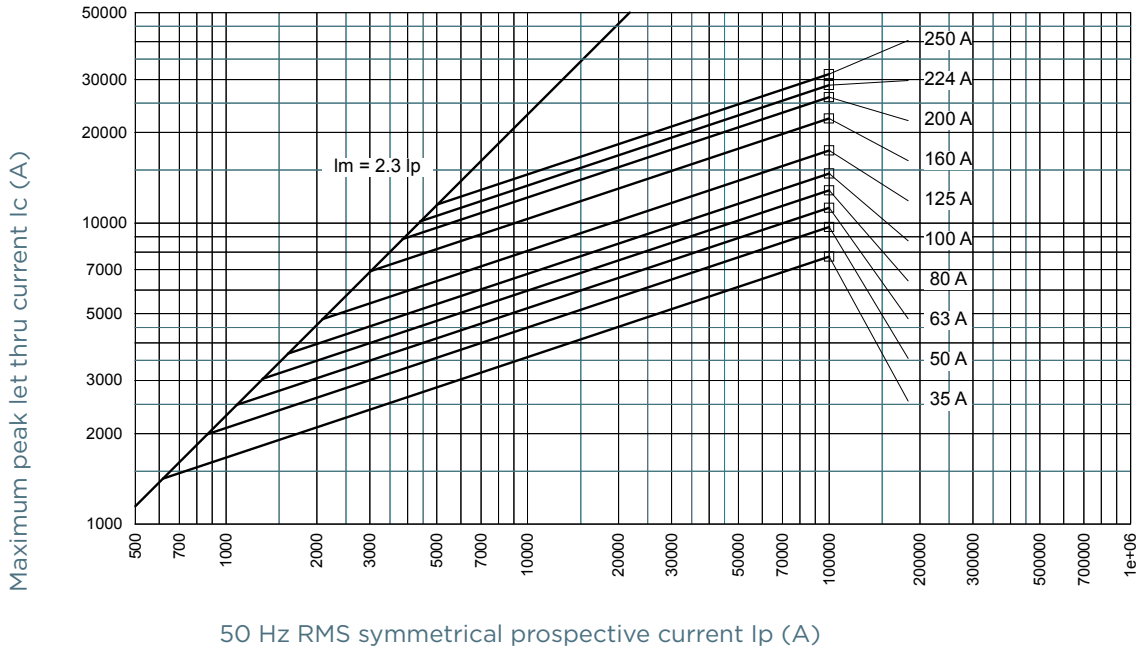

Size 2

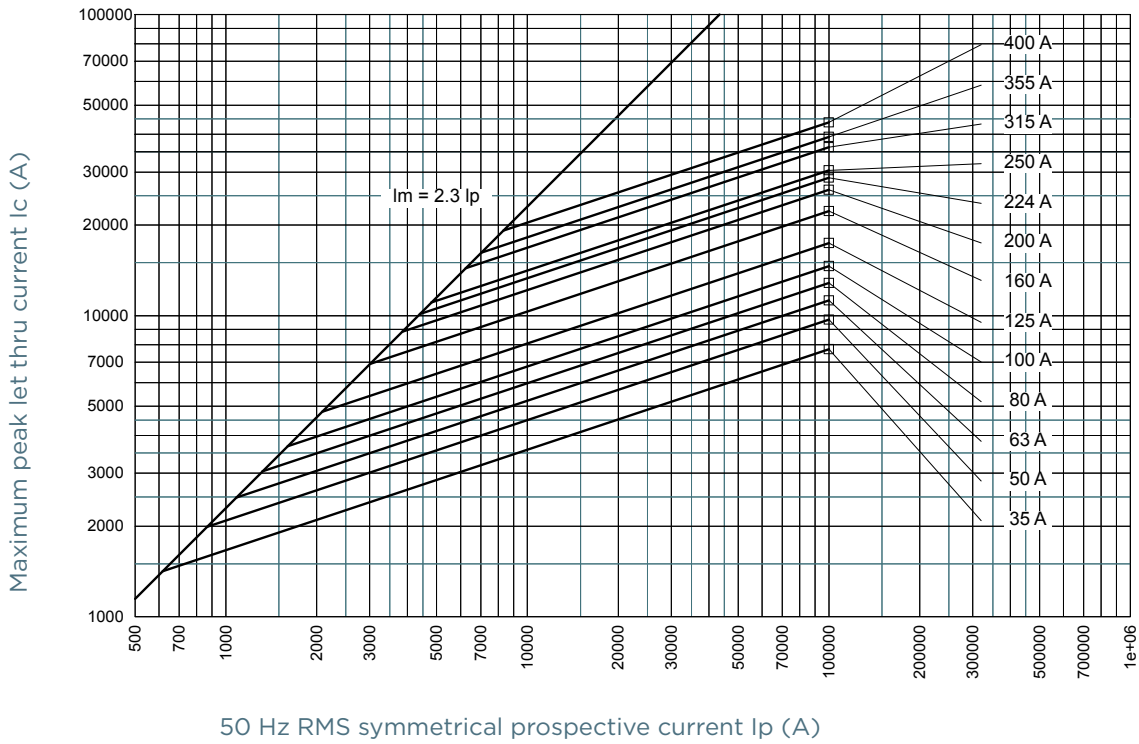

CUT-OFF CURRENT CHARACTERISTIC

Size 3

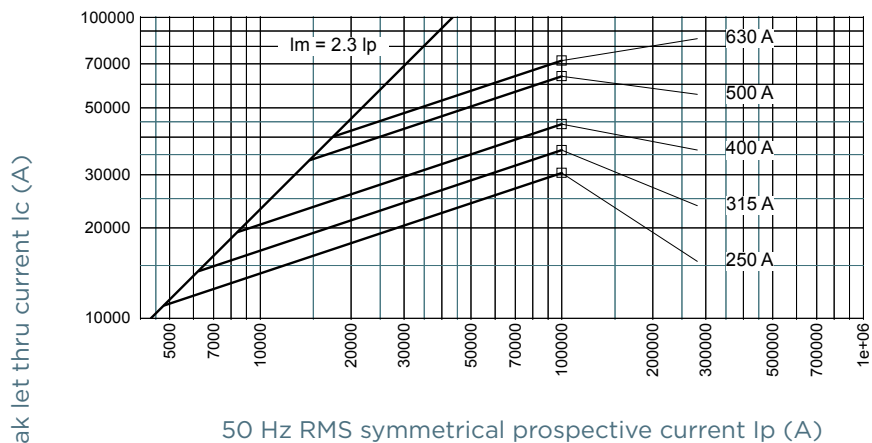

NH fuse-links gG 400VAC

double indicator/isolated gripping-lugs size 000, 00, 1, 2, 3

PRE-ARCING AND OPERATING I²t CHARACTERISTICS

Size 000

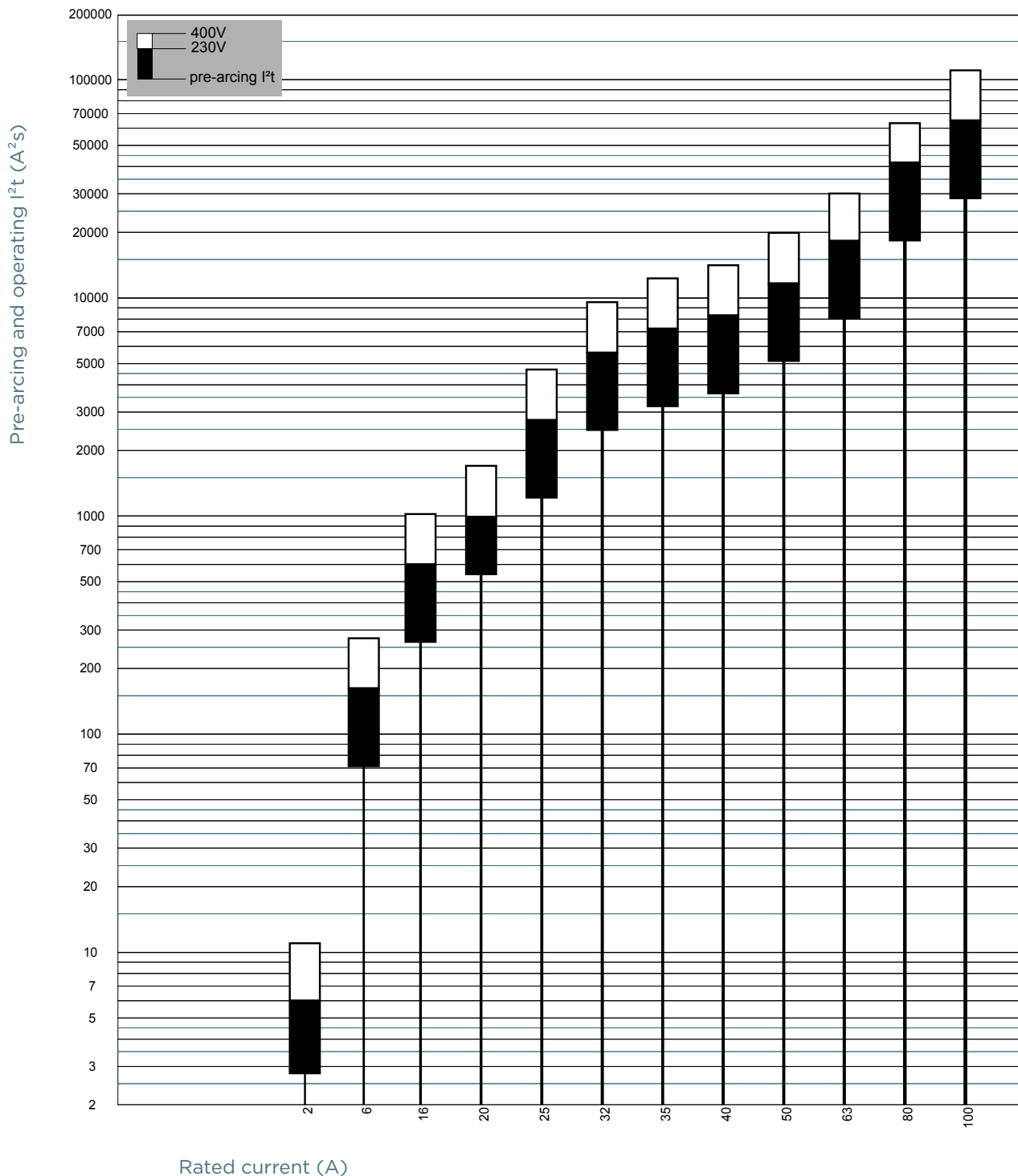

MERSEN reserves the right to change, update or correct, without notice, any information contained in this datasheet.

NH fuse-links gG 400VAC

double indicator/isolated gripping-lugs size 000, 00, 1, 2, 3

PRE-ARCING AND OPERATING I²t CHARACTERISTICS

Size 00

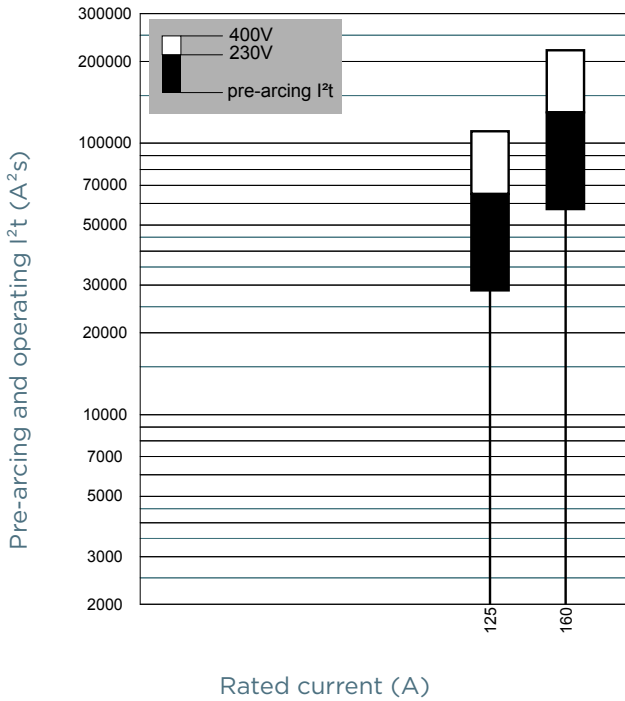

Size 1

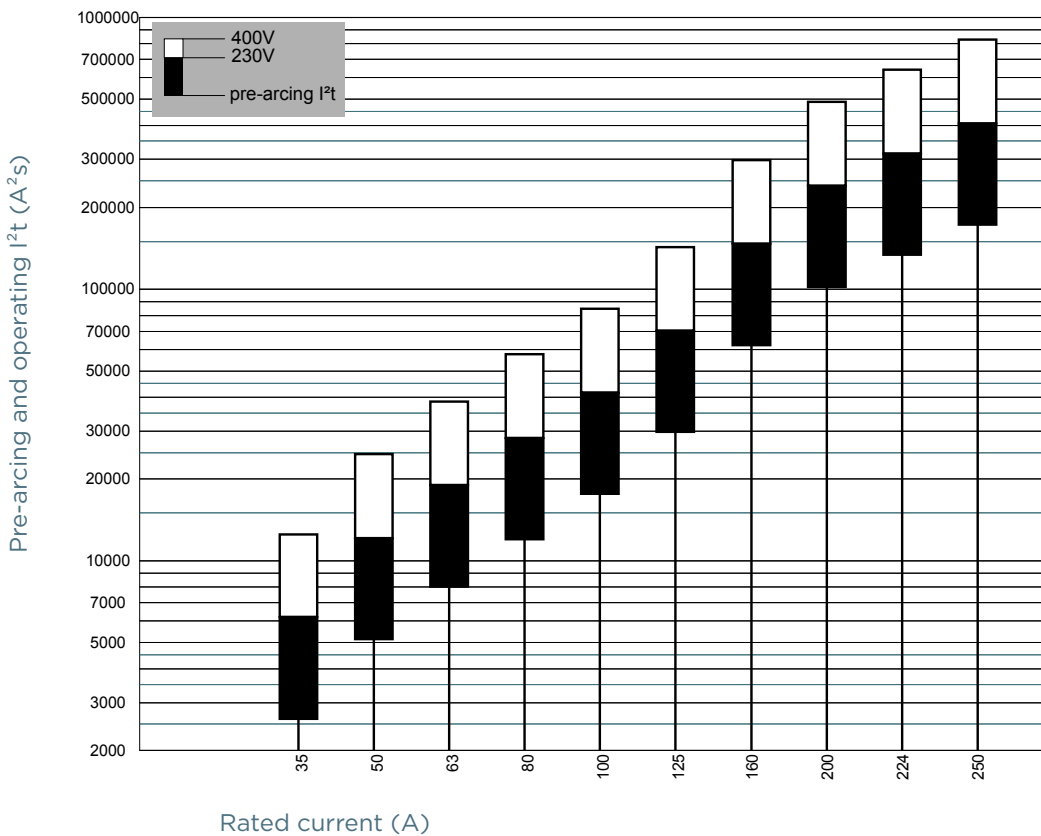

MERSEN reserves the right to change, update or correct, without notice, any information contained in this datasheet.

PRE-ARCING AND OPERATING I²t CHARACTERISTICS

Size 2

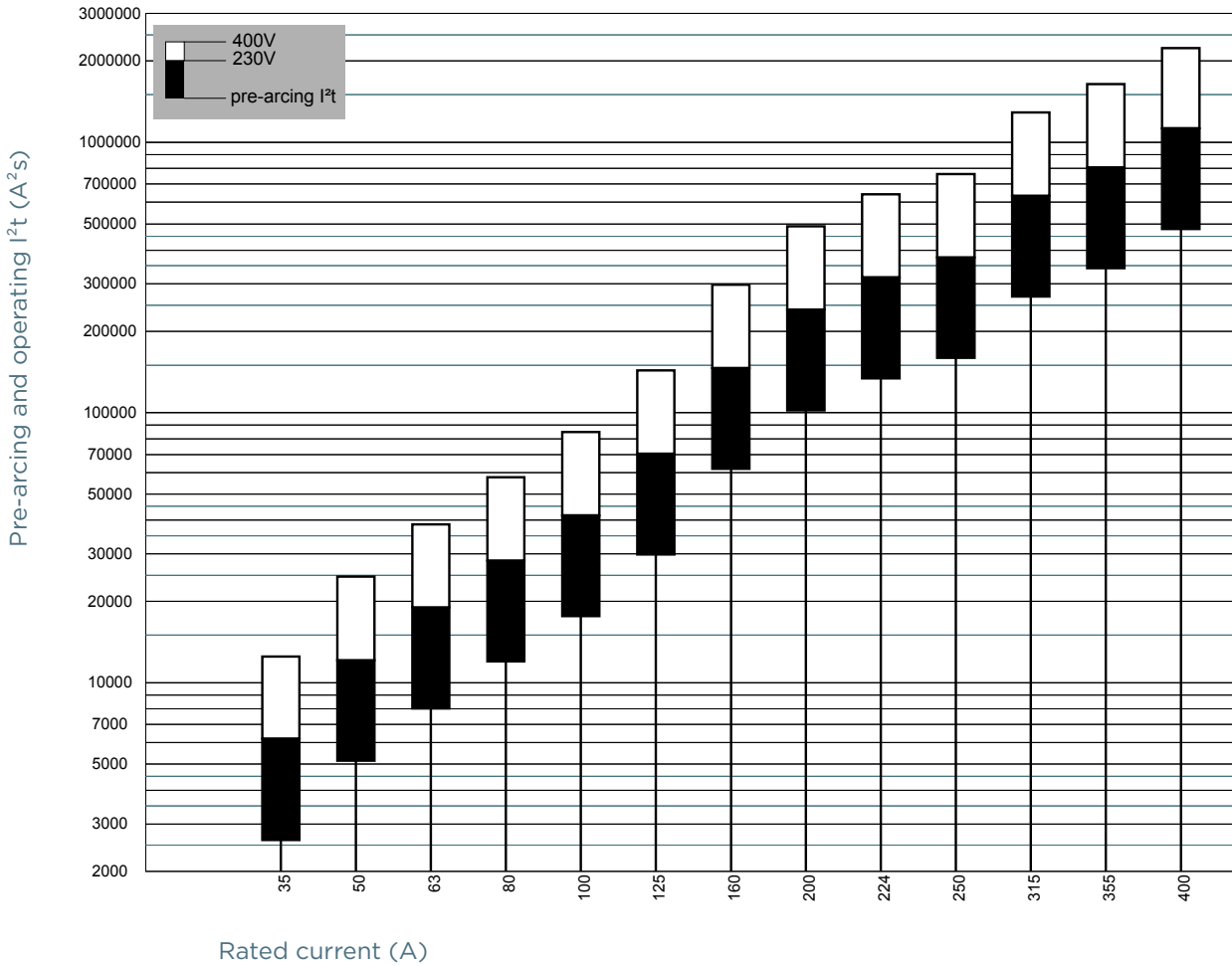

MERSEN reserves the right to change, update or correct, without notice, any information contained in this datasheet.

NH fuse-links gG 400VAC

double indicator/isolated gripping-lugs size 000, 00, 1, 2, 3

PRE-ARCING AND OPERATING I²t CHARACTERISTICS

Size 3

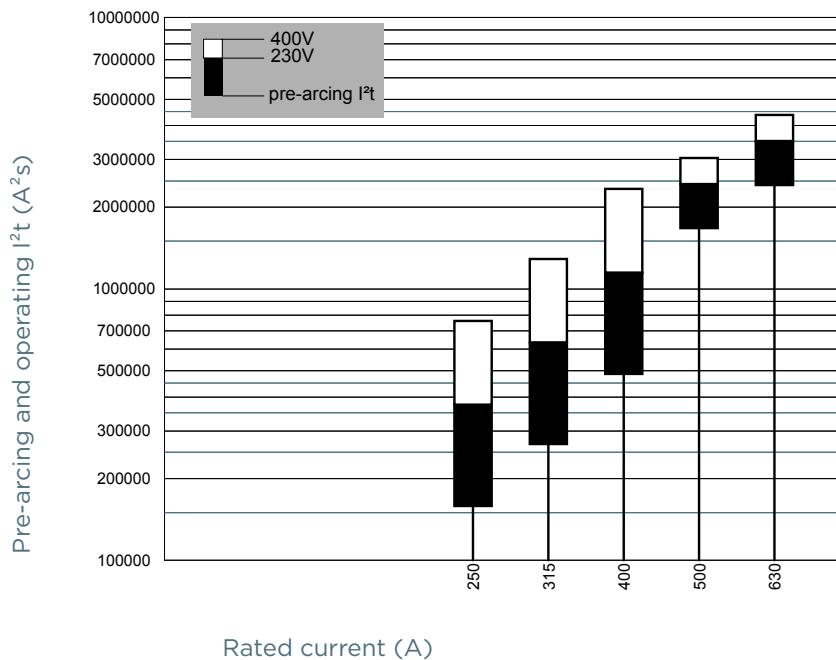

NH fuse-links gG 400VAC

double indicator/isolated gripping-lugs size 000, 00, 1, 2, 3

DIMENSIONS

Size 000 with double indicator (1000405A)

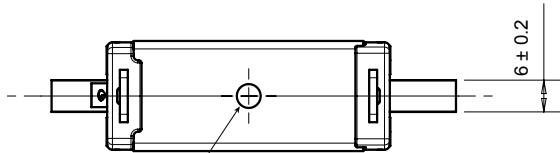
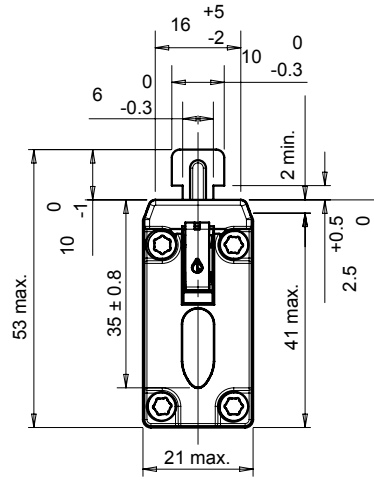
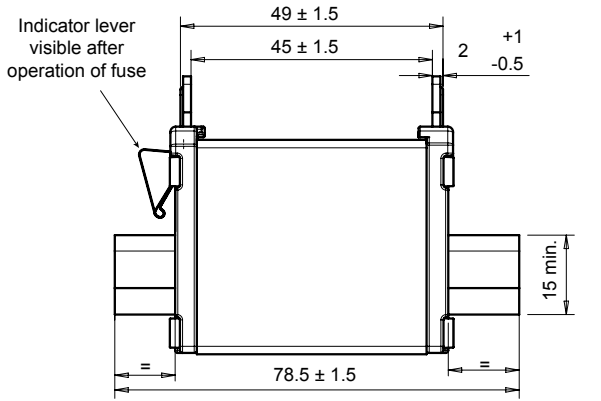

Indicator lever visible after operation of fuse

Visibility of red indicator signals conduction of the fuse-link. After operation the red indicator is no longer visible

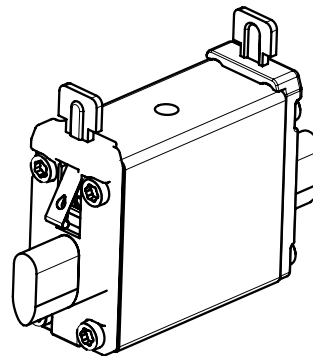

Dimensions in mm

MERSEN reserves the right to change, update or correct, without notice, any information contained in this datasheet.

NH fuse-links gG 400VAC

double indicator/isolated gripping-lugs size 000, 00, 1, 2, 3

DIMENSIONS

Size 00 with double indicator (1000406A)

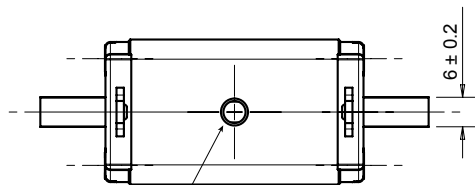
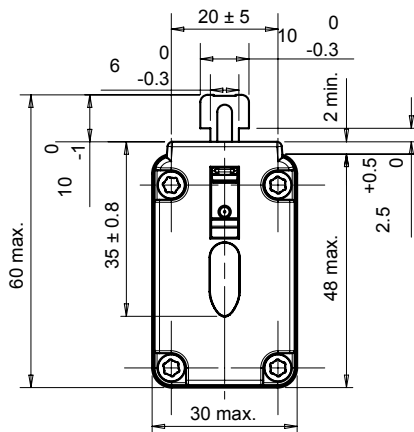
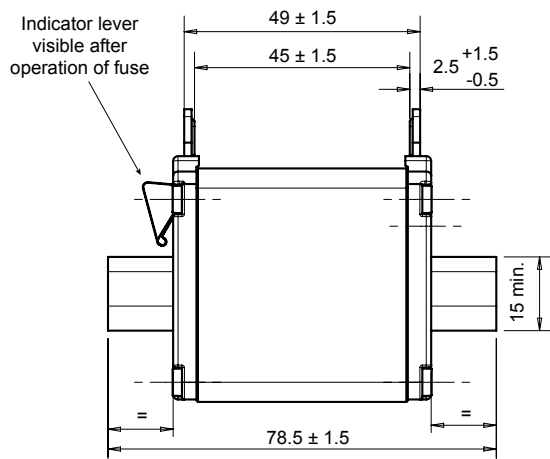

Visibility of red indicator signals conduction of the fuse-link.
After operation the red indicator is no longer visible

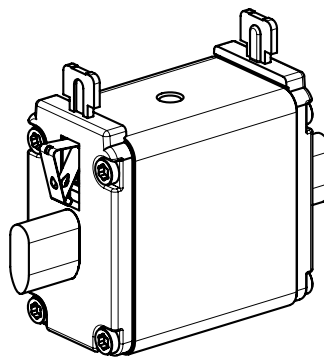

Dimensions in mm

NH fuse-links gG 400VAC

double indicator/isolated gripping-lugs size 000, 00, 1, 2, 3

DIMENSIONS

Size 1 compact with double indicator (35-125A) (1000586A)

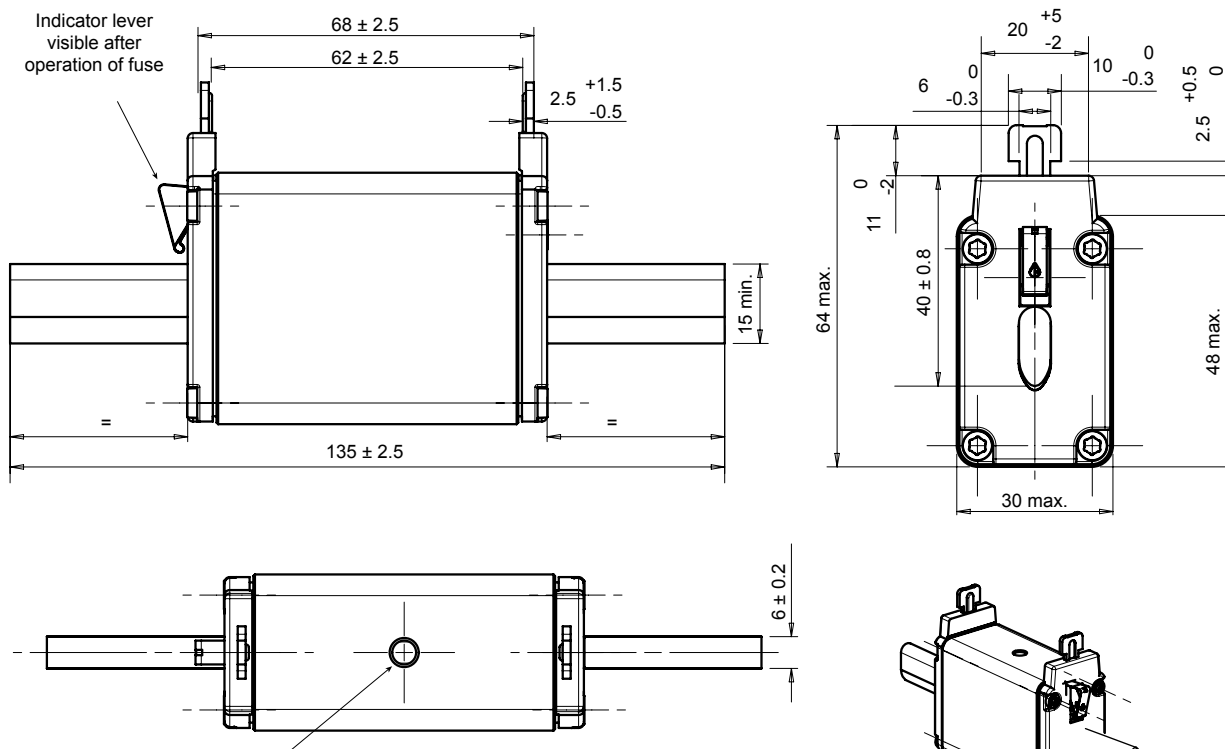

Visibility of red indicator signals conduction of the fuse-link.
After operation the red indicator is no longer visible

Dimensions in mm

NH fuse-links gG 400VAC

double indicator/isolated gripping-lugs size 000, 00, 1, 2, 3

DIMENSIONS

Size 1 with double indicator (160-250A) (1000408A)

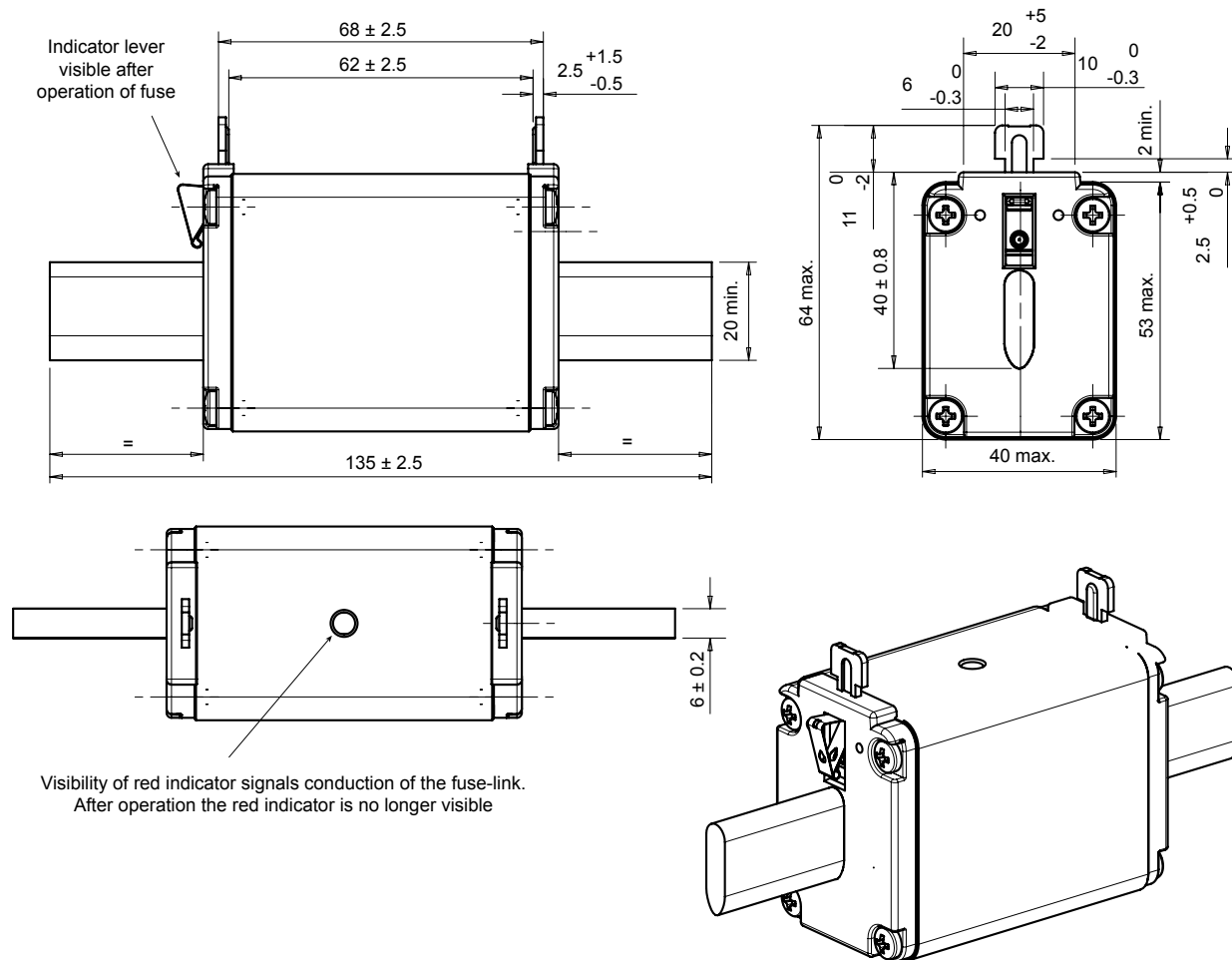

Dimensions in mm

NH fuse-links gG 400VAC

double indicator/isolated gripping-lugs size 000, 00, 1, 2, 3

DIMENSIONS

Size 2 compact with double indicator (35-250A) (1000584B)

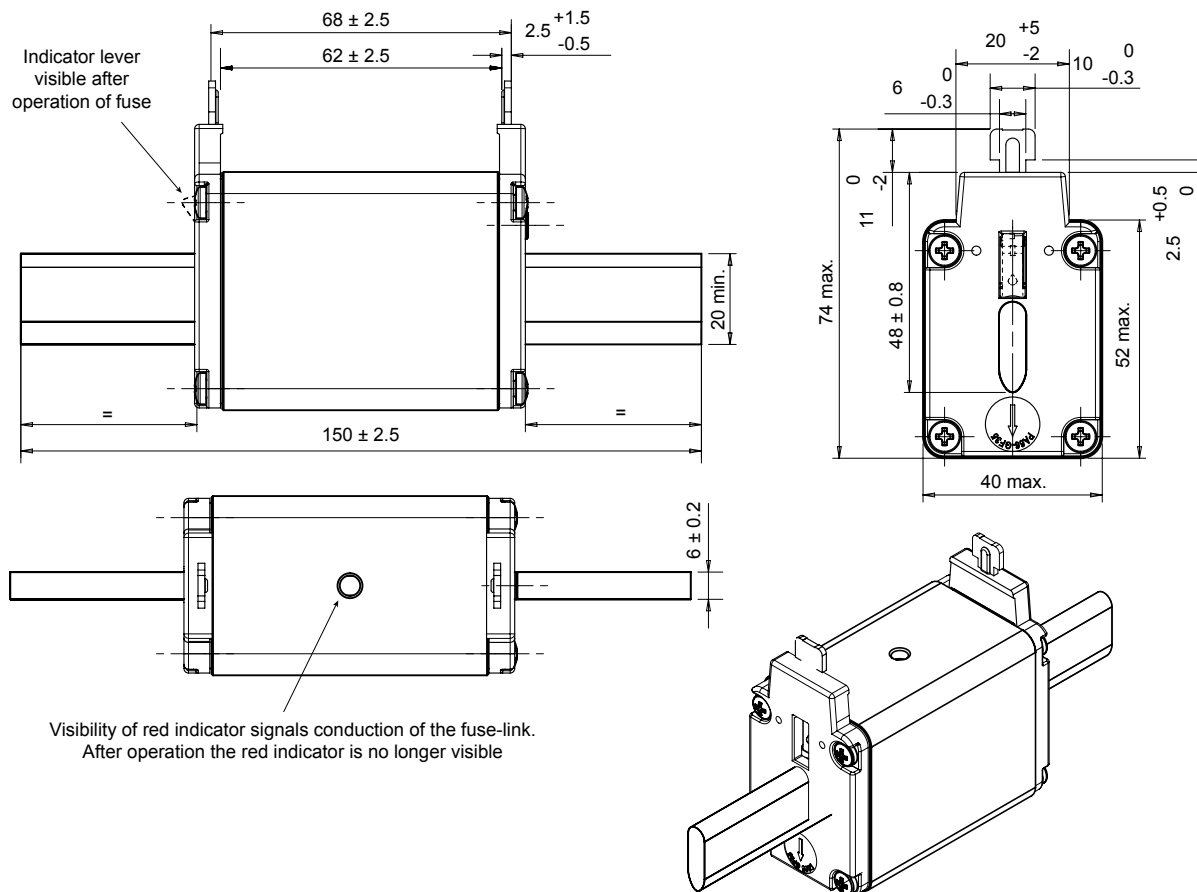

Dimensions in mm

MERSEN reserves the right to change, update or correct, without notice, any information contained in this datasheet.

NH fuse-links gG 400VAC

double indicator/isolated gripping-lugs size 000, 00, 1, 2, 3

DIMENSIONS

Size 2 with double indicator (315-400A) (1000409A)

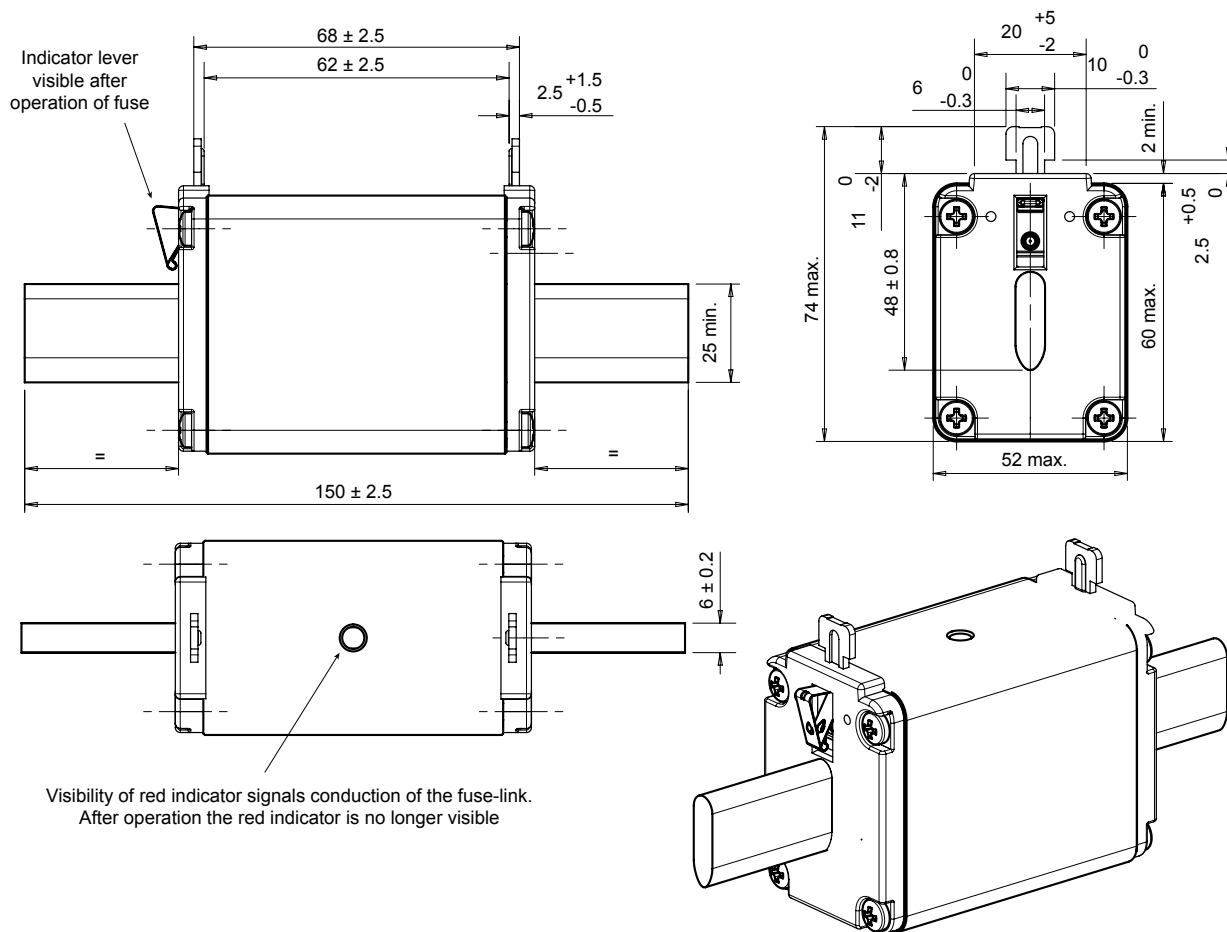

Dimensions in mm

NH fuse-links gG 400VAC

double indicator/isolated gripping-lugs size 000, 00, 1, 2, 3

DIMENSIONS

Size 3 compact with double indicator (250-400A) (1000583A)

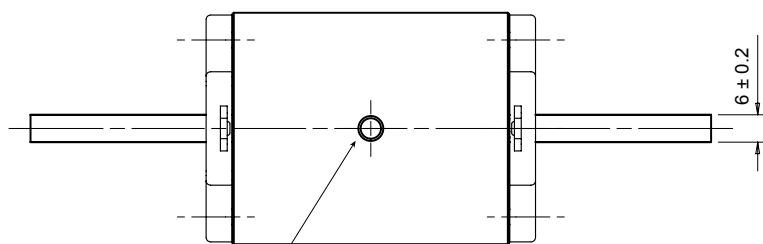
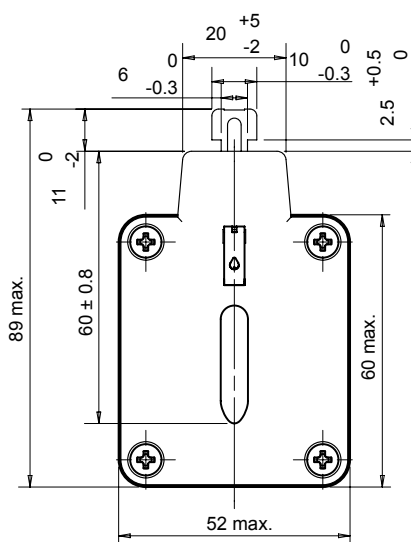
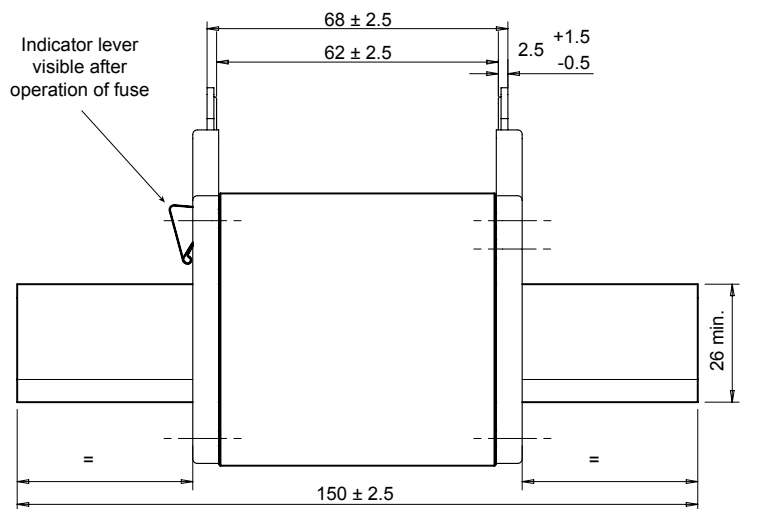

Visibility of red indicator signals conduction of the fuse-link.
After operation the red indicator is no longer visible

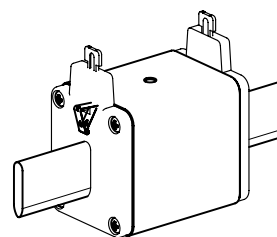

Dimensions in mm

NH fuse-links gG 400VAC

double indicator/isolated gripping-lugs size 000, 00, 1, 2, 3

DIMENSIONS

Size 3 with double indicator (500-630A) (1000410A)

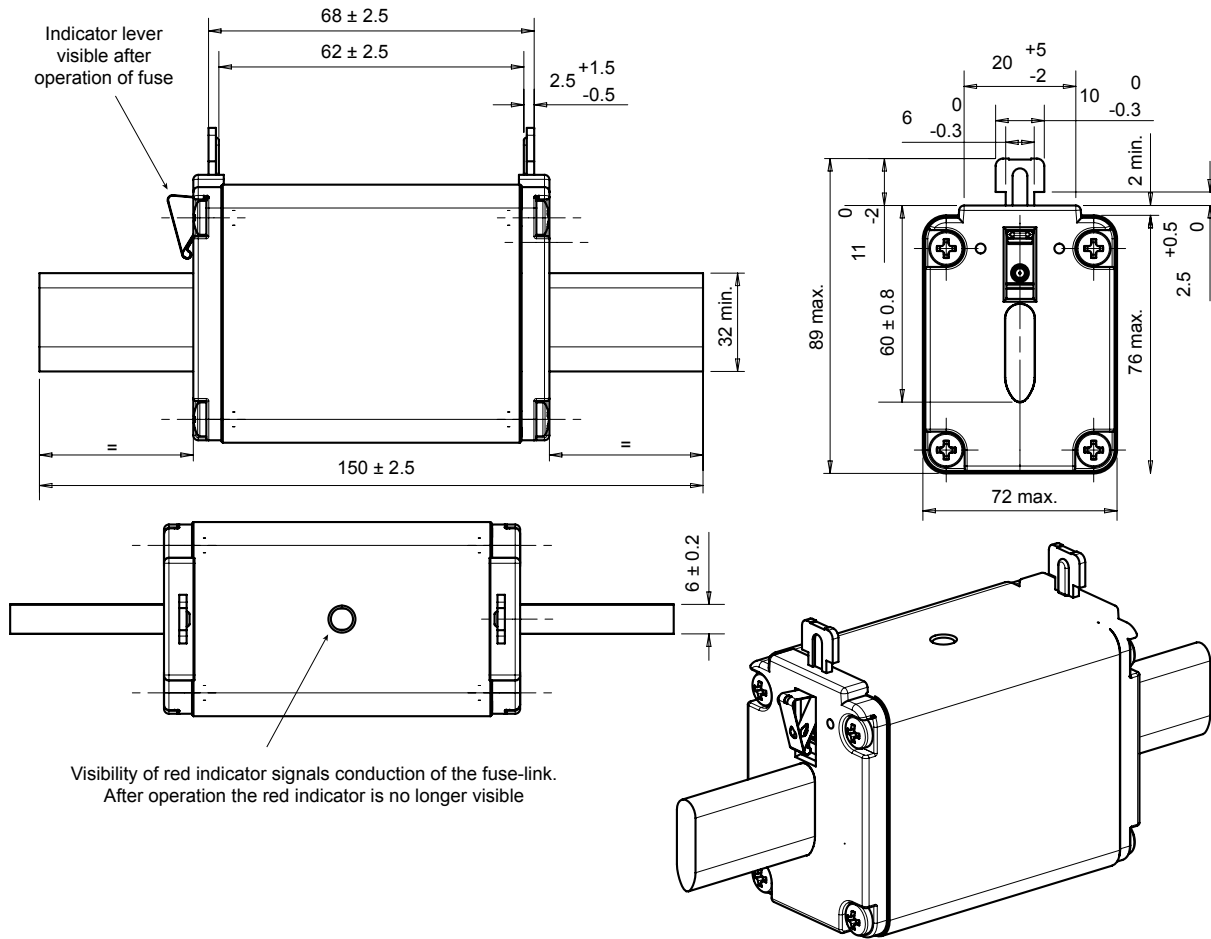

Dimensions in mm